



11/14/2018

Mr. David Wright
Vehicle Programs and Compliance Division
Environmental Protection Agency
2000 Traverwood,
Ann Arbor, MI 48105

Subject: Request for issuance of a new certificate of Conformity – Initial application for MY2019 Model 3 - Long Range AWD, Long Range AWD Performance

Tesla, Inc. requests that the EPA issue a Certificate of Conformity for the subject test group.

Attached to this request is the Part 1 Application. Tesla believes that the test group complies with all applicable regulations contained within Title 40 of the CFR, California Amendments to Subparts B, C, and S, Part 86 and Part 88, Title 40 of the CFR and Title 13 of the California Code of Regulations

Vehicle Category:	Light Duty Vehicle (< 8000 lbs. GVW)
Durability Group:	KTSLV00.0L23
Test Group:	KTSLV00.0L23
Summary Sheet No:	NA
Durability Group Description:	NA
Durability Vehicle:	NA
OBD Group:	NA
Test Group Description:	Tesla differentiates test groups based on: 1) battery type, 2) number of drive motors, and 3) vehicle line. L - Lithium Ion Battery 2 - AWD Motor 3 - Model 3 Line of vehicles
Applicable Standards:	FEDERAL Tier 3 BIN 0 & CALIFORNIA ZEV
Carlines Covered by this certificate:	Model 3 - Long Range AWD, Long Range AWD Performance

Your early review and issuance of the certificate will be greatly appreciated. If you have any questions, please contact me at our office at (510) 249-3755

Sincerely,

Suraj Nagaraj
Director - Vehicle Homologation

Contents

1	
1.01	
01.01.01	
01.01.02	
3	Communications
	Mailing information
	Certification information
	Responsible official
	Facilities, Equipment and Test Procedures
3.01	Procedure to determine mass emissions of the fuel fired heater
3.02	Battery pre-conditioning procedures
3.03	Vehicle Configuration and sub-configurations
3.04	Test Procedures
4	Statement of Compliance
5	Reserved
6	Maintenance
6.01	Test vehicle scheduled maintenance
6.02	recommended customer maintenance schedule
6.03	Lubricants and heater fuels
7	Labels
7.01	Label locations
7.02	Sample emission control information label
7.03	California Environmental Performance Index label: 2015 and later model years
7.04	Projected sales information
8	General Technical Description
8.01	Description of propulsion system
8.02	Description of motor(s)
8.03	Description of batteries
08.03.01	Battery charging capacity
08.03.02	Self-discharge information
08.03.03	Description of thermal management system
08.03.04	Definition of end-of-life
08.03.05	Description of battery disposal plan
8.04	Description of controller / inverter
8.05	Description of transmission
8.06	Description of climate control system
08.06.01	Electric heat pump
08.06.02	Fuel-fired heater
08.06.03	Climate control system logic
08.06.04	Tamper resistance of climate control system that includes a fuel-fired heater
8.07	Description of regenerative braking system
08.07.01	Control logic
08.07.02	Percentage of braking performed on road by each axle
8.08	Description of charger
08.08.01	Proper recharging procedures
08.08.02	Power requirements necessary to recharge vehicle
8.09	Accessories which draw energy from the batteries
8.10	Other unique features (solar panels)
8.11	Description of warning system(s) for maintenance / malfunction
08.11.01	Cut-off terminal voltages for prevention of battery damage
9	Running Change vehicle description
10	Road load data
11	Starting and shifting schedules
11.01	Starting
11.02	Shifting
12	Reserved
13	Reserved
14	Reserved
15	Reserved

16	Reserved
17	California Requirements
17.01	Statement of compliance
17.01.01	General statement
17.01.02	Driveability statement
17.02	Supplemental data and certification review sheets
	Engineering evaluation of zero evaporative emissions under any and all operating conditions (for vehicles equipped with fuel-fired heater only)
17.03	Credits
17.04	Description of multi-manufacturer agreements
17.04.01	Credit calculation
17.04.02	Vehicle safety
17.05	All information on safe handling of vehicle
17.05.01	Information on safe handling of battery system
17.05.02	Description of emergency procedures
17.05.03	
17.06	Description of fuel-fired heater / fuel tank evaporative system
18	Fuel Economy Data Vehicle and De-Rating calculations

1 COMMUNICATIONS

1.01 Mailing information

01.01.01 Certification information

Tesla, Inc
3500 Deer Creek Road
Palo Alto, CA 94304

01.01.02 Responsible officials

01.01.03 - Primary Contact

Mr. Suraj Nagaraj, Director- Vehicle Homologation
Telephone 510 249 8749

01.01.04 - Secondary Contact

Al Prescott, Director - Regulatory Affairs
Telephone 240-994-5639

3 FACILITIES, EQUIPMENT AND TEST PROCEDURES

Internal range test reports are on file at Tesla

3.01 Procedure to determine mass emissions of the fuel-fired heater

Not applicable; vehicle not equipped with a fuel fired heater.

3.02 Battery pre-conditioning procedures

The lithium ion battery cells are cycled by the battery cell manufacturer before they are assembled into battery packs. There is no further pre-conditioning necessary.

3.03 Vehicle Configurations and sub configurations

Refer to Appendix 03.03

3.04 TEST PROCEDURES

SAE J1634 (as revised 2012-10) was followed for all Range testing and SAE J2263 (as issued 1996-10) was followed for Road load measurement.

SPECIAL TEST INSTRUCTIONS

This vehicle shall only be tested on a 4 wheel dyno.

Vehicle Settings

- o Battery stabilized on the vehicle for 1000 miles.
- o Vehicle charged to 100% SOC
- o Dyno Mode ON – This setting prevents TC faults.
- o Regen – Standard
- o Climate OFF
- o Headlights OFF
- o Screen brightness set to default (50%)
- o Radio OFF

Instrumentation

- o Battery voltage and Current measurement – Hioki 3390-10
- o AC recharge – Hioki 3390-10

Lock car upon exit

Pic of Car on Dyno - Tesla Fremont Facility



Pic of Hioki connection - Rear Motor



Pic of Hioki connection - Front Motor



Pic of Hioki connection - High Voltage Ancillaries (Compressor)



Pic of Hioki connection - DC/ DC to HV BUS

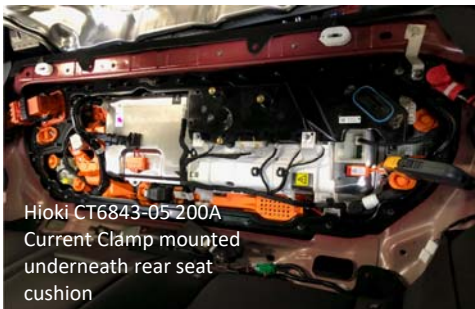

Pic of Front strap to tie on dyno



Pic of rear strap to tie on dyno



04.00 Statement of Compliance

This vehicle conforms to US EPA Federal Tier 3 Bin 0 and State of California regulations applicable to 2019 Model Year new ZEV Light-duty Vehicles

05.00 RESERVED

06.00 MAINTENANCE

6.01 Test vehicle scheduled maintenance

Not applicable.

6.02 Recommended customer maintenance schedule

See Owner Hand Book.

6.03 Lubricants and heater fuels

Heater fuel:	Not applicable
Transmission Lubricant:	Factory Fill
Capacity	2750 mL (Rear), 1755 mL (Front)
Make	SK
Trade name	ZIC ATF - 9
Type	Synthetic
Viscosity	7100 cP at -40°C
Viscosity	5.9 cSt at 100°C

Test Vehicle

Same as factory fill

07.00 LABELS

07.01 Label locations

VECI Emission Label

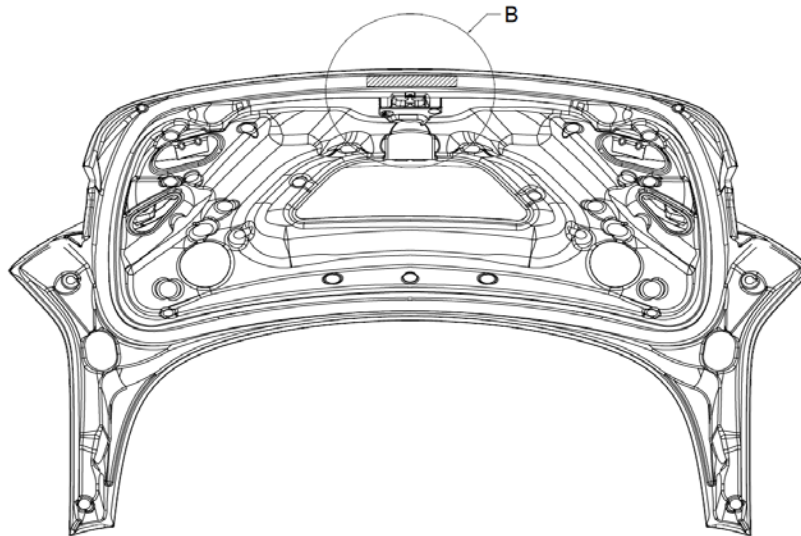

See 07.02

Monroney Label

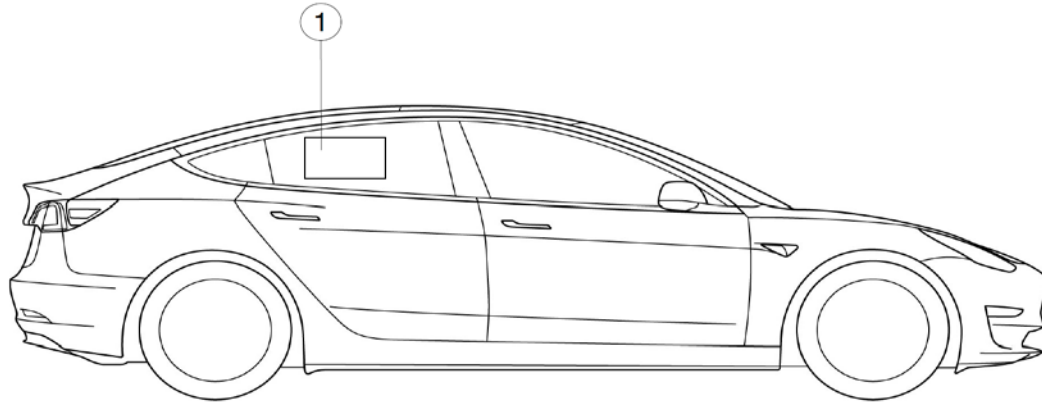

See 07.03

07.02 Emission Control Information label: 2019 Model Year

(Mandated in CFR Title 40, Part 86; §86.1807. Label format agreed with EPA)



07.03 California Environmental Performance Index label: 2019 Model Year

(Mandated in California Environmental Performance Label Specifications for 2009 and Subsequent Model Passenger Cars, Light-Duty Trucks and Medium-Duty Passenger Cars. Label format agreed with EPA/ CARB)

Model 3 Long Range AWD - FE Label

EPA DOT Fuel Economy and Environment **Electric Vehicle**

Fuel Economy These estimates reflect new EPA methods beginning with 2017 models. **You save \$4,000 in fuel costs over 5 years compared to the average new vehicle.**

116 **MPGe** Midsize cars range from 14 to 136 MPGe. The best vehicle rates 136 MPGe.
combined city/hwy city highway kW-hr per 100 miles

120 **112** **29**

Driving Range When fully charged, vehicle can travel about... **310 miles**
Charge Time: 10 hours (240V)

Annual fuel cost \$550

Fuel Economy & Greenhouse Gas Rating (tailpipe only) **10** **10** Best
Smog Rating (tailpipe only) **10** **10** Best

This vehicle emits 0 grams CO₂ per mile. The best emits 0 grams per mile (tailpipe only). Producing and distributing fuel also create emissions: learn more at fueleconomy.gov.

Actual results will vary for many reasons, including driving conditions and how you drive and maintain your vehicle. The average new vehicle gets 27 MPG and costs \$6,750 to fuel over 5 years. Cost estimates are based on 15,000 miles per year at 0.13 per kW-hr. MPGe is miles per gasoline gallon equivalent. Vehicle emissions are a significant cause of climate change and smog.

fueleconomy.gov
Calculate personalized estimates and compare vehicles

Smartphone QR Code
<http://fueleconomy.gov/g/14-2018TSL035>

Model 3 Long Range AWD Performance - FE Label

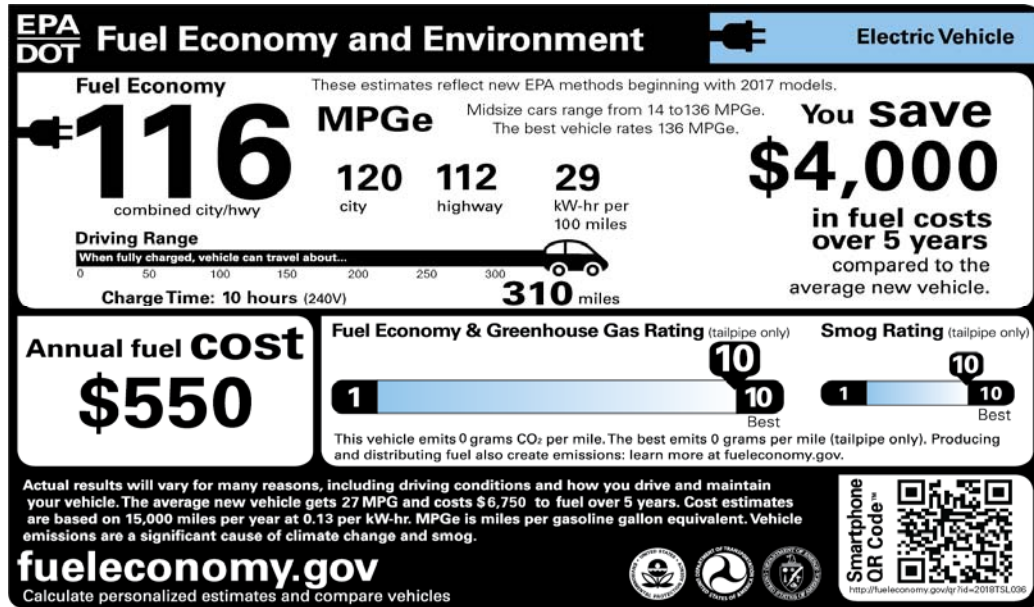

07.04 Projected sales information (Confidential)

08:00 GENERAL TECHNICAL DESCRIPTION

08.01 DESCRIPTION OF PROPULSION SYSTEM

The propulsion system consists of two drive units and a high voltage battery pack. Each drive unit contains an inverter, an electric traction motor, a fixed-ratio gearbox, and a differential.

8.02 DESCRIPTION OF MOTOR(S)

The front motor is a 3-Phase AC induction motor utilizing a squirrel cage 4 pole, variable frequency drive to control the motor. The rear motor is a 3-phase AC internal permanent magnet motor utilizing a six-pole, high-frequency design with inverter-controlled magnetic flux.

8.03 DESCRIPTION OF BATTERIES

The battery packs used in the Tesla Model 3 is one of the most technically advanced lithium-ion battery packs in the world. Using customized automotive grade lithium-ion cells, the Tesla battery achieves unmatched energy density and enables the long range capability of the vehicle. The low-profile flat packaging enables an efficient and functional occupant area. The battery has replaceable active short circuit protection that is accessible with the battery in the vehicle via an access panel. A set of switches inside the pack disconnect high voltage from the positive and negative terminals on the battery pack when not in use. To disable the switches from closing during vehicle service, the 12V power feed can be disconnected at the low voltage wiring connector into the battery pack. The battery control system consists of the Battery Monitoring System (BMS) which controls the switches, measures pack current and voltages, electrical isolation of the battery from chassis ground and monitors cell voltages and module temperatures from the Battery Monitor Boards (BMBs) installed on each of the modules. The battery is rated at 400V and is capable of delivering in excess of 1000 Amperes. The battery mass is less than 500 kg.

08.03.01 Battery charging capacity

The fully charged battery contains a minimum amount of usable energy when new, based on the battery type/option fitted to the vehicle.

08.03.02 Self-discharge information

The self-discharge rate of the High Voltage battery is likely to be less than 0.5% per month.

08.03.03 Description of thermal management system

The Tesla battery pack contains an integrated cooling system to ensure that the individual cells are maintained at, or close to, their optimum operating temperature. Incorporated in the vehicle system is an inline heating element to raise and a chiller to lower the pack temperature, when required.

08.03.04 Definition of end-of-life

The battery pack end-of-life shall be determined by Tesla's local service centers with Proper inspection and test methods.

08.03.05 Description of battery disposal plan

Tesla's lithium ion battery packs do not contain heavy metals such as lead, Cadmium, or mercury. They are exempt from hazardous waste disposal standards in the USA under the Universal Waste Regulations. However, they do contain recyclable materials, and Tesla plans to recycle all battery packs removed from vehicles.

Tesla highly recommends that all battery packs be taken to local Tesla service facilities and recycled by Tesla or Tesla authorized agencies, so that the battery packs can be recycled in a safe and efficient manner.

If disposing independently, without return to Tesla, then the owner must assume responsibility for recycling in a safe and legal manner. If an owner does assume this responsibility, Tesla recommends consulting with the appropriate local, state or federal authorities to determine the appropriate methods for disposal and recycling. Keep in mind that disposal regulations may vary dependent on location.

For more information on the recycling of Tesla custom battery packs, please call Tesla Customer Service at 1-877-79TESLA (1-877-798-3752).

08.04 DESCRIPTION OF CONTROLLER / INVERTER

The drive inverter performs several critical functions in the Tesla Model 3 including torque control, power and torque limit enforcement, and status monitoring. The drive inverter is an integral part of the drive unit.

08.05 DESCRIPTION OF TRANSMISSION

The transmission is a fixed ratio, mechanical, transversely mounted gearbox with integral final drive (transaxle configuration).

The shift lever is mounted to the steering column. The lever has five detents— that can select Reverse, Neutral, Drive, Cruise and Autopilot (if equipped). Selecting either forward or reverse position enables drive current to the motor to generate the appropriate torque. There is no physical reverse gear needed.

In addition, the lever has a park button which is used to operate the electrically-actuated park brake.

Transmission Shift lever - Steering column



8.06 DESCRIPTION OF CLIMATE CONTROL SYSTEM

General Specifications:

The Model 3 climate control is a Dual Zone system with Automatic Temperature control. The modes include Defrost, Panel and Floor (or any combination of these three). The system consists of two panel vents, two front row floor vents, defroster vent, second row floor vents, second row console vents with positive air shut off and turning vane manual control.

08.06.01 Electric cabin heater

The heater unit incorporating a variable speed electric fan is located in the front of the chassis tub with ducting directing the blown air to defrosting, face level and floor level vents in the passenger compartment. The heater element is of the positive temperature coefficient (PTC) type, drawing HV electrical energy from the battery pack High Voltage.

08.06.02 Fuel-fired heater

Not applicable

08.06.03 Air conditioning

The Model 3 air conditioner system is an R134a refrigerant consists of a high voltage electric scroll type with integrated inverter with High Voltage Interlock Loop. The compressor Oil is Poly Olefin Ester oil that is non-conducting.

08.06.04 Climate control system logic

Vehicle Controller printed circuit boards activate actuators and responds to evaporator air outlet temperature sensor, PTC heater outlet temperature sensor and air duct temperature sensors, as well as user demands from center display.

08.06.05 Tamper resistance of climate control system that includes a fuel-fired heater

Not applicable

08.07 DESCRIPTION OF REGENERATIVE BRAKING SYSTEM

Regenerative braking (RGB) occurs when the driver lifts his foot from the accelerator pedal while the vehicle is moving; the experience is analogous to engine braking on a gasoline-powered car with a conventional manual transmission. The friction braking system is independent of RGB.

The amount of RGB torque generated depends on the accelerator pedal position – largest when the accelerator pedal is fully released, decreasing as the pedal is depressed, reaching zero torque when the pedal reaches its neutral torque position (a position that is a function of vehicle speed). The max RGB deceleration also varies depending on vehicle speed. The maximum RGB profile is defined as a target total deceleration rate as a function of vehicle speed. The max RGB profile is tailored to everyday driving conditions, which typically exhibit higher deceleration rates at lower speeds.

When the battery pack is near maximum capacity, regenerative braking function will be limited to ensure the maximum capacity of the battery is not exceeded. Any RGB limiting will be ramped in gradually to allow the driver to adapt to the changing RGB performance. When the battery pack is below 0 degrees, RGB will not be allowed because the batteries are not rated to accept charge below this temperature. Any RGB limiting will be ramped in gradually to allow the driver to adapt to the changing RGB performance. The vehicle notifies the driver of any limits on the regenerative braking function.

08.08 DESCRIPTION OF VEHICLE ELECTRICAL SUPPLY EQUIPMENT (CHARGER)

The Tesla Model 3 is capable of accepting energy either from a permanent facility installed at the owners location or from many readily available power outlets when 'on the road'.

Optional - The dedicated High Power Connector (HPC) can be purchased separately from the vehicle and a certified electrician will confirm the capabilities of the residential supply circuit at the vehicle owner's location. Confirmation of a satisfactory residential electrical Supply will lead to the installation of a hard-wired HPC unit, this will expedite vehicle charging at the most efficient rate. The HPC can supply available current up to a maximum of 80 amps and incorporates electronic systems that communicate with the vehicle control systems to indicate the maximum available current so that the vehicle can determine the amount and rate of charge required. But the current standard on-board charger is limited to 48A. So the charging duration is 8.5 hrs. at the rate of 48 Amps.

Standard - Charging at rates lower than or equal to 32A can also be achieved via a mobile connector. The universal mobile connector is included as standard in the purchase of every Model 3 and is an individual cable that connects the vehicle to any available domestic power outlet and can deliver current to a maximum of 32 Amps. The Mobile Connector incorporates similar electronic circuitry as the HPC to communicate with the vehicle and manage the charging process. The charging duration is 12 hrs. at the rate of 32 Amps.

The vehicle is also capable of accepting DC current up to 525A from an off-board charger (Supercharger).

08.08.01 Proper recharging procedures

The charging system adjusts automatically to the available AC line voltage, frequency and current, within limits. The charging system in the vehicle works in conjunction with either of the three external charging stations; the permanently installed HPC, the permanently installed supercharger or the portable Mobile Connector.

Anytime the EV Inlet door is opened, the vehicle will prepare to enter CHARGE state. Once the user connects either supply cable to the vehicle, the charging system signals to the vehicle that it is ready to deliver the charge. The vehicle locks the cable onto the vehicle and then indicates that it is ready to accept energy and charging will commence. Failure of any of these steps will result in fault condition and lack of **full charging capability**. Vehicle could still charge on low power if handle lock is not engaged.

Prepare to charge state



Low Power Charging Indication



High Power Charging Indication



If the battery temperature is near or below freezing temperatures, normal charging will not occur. The vehicle will identify this condition and will begin heating the battery coolant and circulating the coolant to raise the battery temperature to enable charge. When the pack temperature rises to a temperature within the allowable charging range, heating will reduce or stop and charging will commence.

08.08.02 Power requirements necessary to recharge vehicle

Model 3 comes with one on-board charger is capable of a maximum of 48A on 208V or 240V outlets and 12A on 120V outlets.

08.10 OTHER UNIQUE FEATURES (i.e. solar panels)

Not applicable; vehicle is not equipped with any such features.

08.11 DESCRIPTION OF WARNING SYSTEM(S) FOR MAINTENANCE / MALFUNCTION

The Tesla Model 3 is equipped with a tell-tale lamp located in the instrument pack to indicate any malfunctions through user alerts e.g. "battery failure" with battery symbol.

The tell-tale is complemented by more detailed information exhibited on the Center Display. An additional driver aid which indicates the nature of the malfunction as well as a wide range of additional vehicle data, such as when maintenance is needed.

08.11.01 Cut-off terminal voltages for prevention of battery damage

The control electronics inside of the Drive Unit and Charger are programmed not to allow the unit to drive the voltage of the battery above or below hard voltage limits. If the battery pack is unable to achieve a desired response from these systems and the voltage reaches above or below a set limit, the two switches inside the battery pack will open, disabling the entire high voltage system in the car.

09.00 RUNNING CHANGE VEHICLE DESCRIPTION

Refer to appendix 09.00, if applicable

10.00 ROAD LOAD DATA

See Verify application

11.00 STARTING AND SHIFTING SCHEDULES

11.01 Starting

The Model 3 does not have a traditional starter switch and instead has a smart entry system for greater safety and customer convenience. The smart entry system comprises of an authenticated phone (using Bluetooth Low Energy or internet connectivity) or key card (using Near Field Communication), a weight sensor embedded into the driver seat, and the brake pedal.

ENTERING

An authenticated phone can be used to passively unlock the car when connected, in range and a door handle is pulled or trunk release button is pressed.

The Tesla mobile app on an authenticated phone can be used to manually unlock the vehicle.

A key card can be used to unlock the car by scanning the card on the b-pillar.

After a successful key card scan on the b-pillar or center console:

- a. Vehicle is authorized to Drive within a reasonable time period. Time period is extended based on additional user interaction which include: driver opening their door, driver sitting down, driver closing their door while seated.
- b. If time period is exceeded, upon brake press, instruct driver to rescan key card on the center console to reauthorize Drive.
- c. Accessory Mode functions will be available without the user having to rescan their key card.

LOCKING

An authenticated phone can be used to passively lock the car when the phone is disconnected or moved away from the vehicle. This passive function can be disabled in controls on the touchscreen.

The Tesla mobile app on an authenticated phone can be used to manually lock the vehicle.

A key card can be used to lock the car by scanning the card on the b-pillar. There is no passive locking with key cards (car does not auto lock).

Note: Using a key card to lock/unlock will be equivalent to an active lock/unlock—i.e., clicking on the key fob to lock and double-clicking to unlock.

STARTING

If successful interaction between authenticated phone or the key card and vehicle controller occurs, the system deactivates the immobilizer. Immobilizer deactivation only happens after 2 conditions are met below. The vehicle then enters accessory mode analogous to a “ACC” position on a conventional IC engine. In this mode, low voltage (12V) is supplied to the vehicle allowing operation of the radio and other accessories connected to the accessory rail.

High Voltage (HV) necessary to enable vehicle propulsion is enabled only by the closing of the contactors, which can only be triggered when the following conditions are both satisfied,

1. Authenticated phone or key card is authorized and key code is validated AND
2. Brake pedal is depressed.

By requiring brake pedal activation, along with the appropriate key code, this system ensures the safety of vehicle occupants by not allowing self mobility of the vehicle without the driver providing proper control inputs (i.e., service brake activation) and appropriate driver authorization (i.e., presence of the key code). If either the service brake is not activated or the key code not present, the vehicle controller will not close the contactors and self-mobility is not possible.

If the brake pedal is depressed and the proper key code present, the drive rail will activate (immobilizer deactivates) and allows the vehicle to be shifted out of Park.

11.02 SHIFTING

Not applicable – the vehicle has a single-speed transmission.

12:00 -16:00 RESERVED

17:00 CALIFORNIA REQUIREMENTS

17:01 Statement of Compliance

17.01.01 General Statement

The production vehicles which are subject to registration or sale in the State of California will be, in all material respects, substantially the same in construction as test vehicles which are certified by the California Air Research Board; and will meet all the applicable emissions standards which are promulgated by the California Air Research Board in accordance with Section 43101 of the Health and Safety Code.

Tesla attests that the vehicle emission control label complies with the label durability requirements of the "California Motor Vehicle Emission Control and Smog Index Label Specifications", Title 13, CCR, Section 1965.

17.01.02 Drivability statement

This statement is no longer included in the California Exhaust Emission Standards and Test Procedures for 2001 and Subsequent Model Passenger Cars, Light-Duty Trucks, and Medium-Duty Vehicles (as of January 01 2006); as was the case in previous versions.

17.02 Supplemental data and certification review sheets

See attached

17.03 Engineering evaluation of zero evaporative emissions under any and all operating conditions (for vehicles equipped with fuel-fired heater only)

Not applicable; vehicle is not equipped with fuel-fired heater.

17.04 Credits

17.04.01 Description of multi-manufacturer arrangements

Not applicable; Tesla has no such agreements in place.

17.04.02 Credit calculation

Tesla a manufacturer that produces only pure battery electric vehicles is not required to produce a percentage of annual production volume as ZEV's and therefore will earn such credit on all 2013 to 2018, inclusive, model year vehicles. This vehicle is a full function ZEV with a range depending on the battery pack option chosen by the customer. Based on the UDDS of range shown in the table below, all variants will be classified as a Type III ZEV and Under the table in 13 CCR 1962.1(d)(5)(C), this means 2013 to 2018, each vehicle will earn 4 credits per vehicle.

Variant	UDDS Range (Miles)
Model 3 Long range AWD	455.32

17.05 VEHICLE SAFETY

17.05.01 All Information for safe operation of vehicle

Tesla will submit a copy of the finalized vehicle owner's handbook by separate letter when it becomes available.

17.05.02 Information on safe handling of battery system

HANDLING

Do not short circuit, puncture, incinerate, crush, immerse, force discharge, or expose the battery pack to temperatures outside the specified maximum storage temperature range of -20°C to 60°C.

The battery pack has a nominal operating voltage of 400 VDC. The battery pack is sealed in a rigid metal case and its exterior is isolated from high voltage. Handling the battery pack is electrically safe provided the enclosure remains closed.

The battery pack contains hermetically sealed lithium ion cells that contain a number of chemicals and materials of construction. Risk of exposure to electrode materials and Liquid electrolyte will only occur in cases of mechanical or thermal abuse of the battery Pack.

STORAGE

Do not store the battery pack in a manner that allows terminals to short circuit. Do not place near heating equipment, nor expose to direct sunlight for long periods. The battery pack should only be stored in approved packaging and stacked no more than two (2) packages high. To maintain service life, the battery pack should be stored at a state of charge (SOC) of 15 to 50%.

TRANSPORT

Lithium ion batteries are regulated as Class 9 Miscellaneous dangerous goods (also known as “hazardous materials”) pursuant to the International Civil Aviation Organization.

(ICAO) Technical Instructions for the Safe Transport of Dangerous Goods by Air, International Air Transport Association (IATA) Dangerous Goods Regulations, the International Maritime Dangerous Goods (IMDG) Code, European Agreements concerning the International Carriage of Dangerous Goods by Rail (RID) and Road (ADR), and applicable national regulations such as the USA’s hazardous materials regulations (see 49 CFR 173.185). These regulations contain very specific packaging, labelling, marking, and documentation requirements. The regulations also require that individuals involved in the preparation of dangerous goods for transport be trained on how to properly package, label, mark and prepare shipping documents.

17.05.03 Description of emergency procedures

HIGH VOLTAGE EXPOSURE

If one of the Tesla products has been visibly damaged or its enclosure compromised, then practice appropriate high voltage preventative measures until the danger has been assessed (and dissipated if necessary).

FIREFIGHTING MEASURES

If a fire or explosion occurs when the battery pack is charging, shut off power to the charger. In case of burning lithium ion fires, flood the area with water. The water may not extinguish them, but will cool the adjacent batteries and control the spread of the fire. CO₂, dry chemical and foam extinguishers are preferred for small fires, but also may not extinguish burning lithium ion batteries. Burning batteries will burn themselves out. Virtually all fires involving lithium ion batteries can be controlled with water. When water is used, however, hydrogen gas may be a by-product which can form an explosive mixture with air. LITH-X (powdered graphite) or copper powder fire extinguishers, sand, dry ground dolomite or soda ash may also be used. These materials act as smothering agents.

Damaged or opened cells or batteries can result in rapid heating (due to exothermic reaction of constituent materials) and the release of flammable vapors. Water (and other items listed above) disperses heat when applied in sufficient quantity to a fire. Extended heat exposure can lead to ignition of adjacent cells with a potential complete envelopment of the battery pack if not cooled. An extinguished lithium ion battery fire can re-ignite due to the exothermic reaction of constituent materials from broken or damaged cells. To avoid this, remove sources of ignition and cool the burned mass by flooding with (or immersing in) water. Fire-fighters should wear self-contained breathing apparatus. Cells or batteries may flame or leak potentially hazardous organic vapors if exposed to excessive heat, fire or over voltage conditions. These vapors include HF, oxides of carbon, aluminum, lithium, copper, and cobalt. Additionally, volatile phosphorus pentafluoride may form at temperatures above 230° Fahrenheit. Never cut into the sealed battery pack enclosure due to the high voltage and electrocution risks.

If a decision is made to fight a battery fire aggressively, then large amounts of water should be applied from a safe distance with the intent of flooding the battery pack enclosure as completely as possible. Alternatively, if a decision is made to fight a battery fire defensively, then the fire crew should pull back a safe distance and allow the battery to burn itself out. Fire crews may choose to utilize a water stream or fog pattern to protect exposures or control the path of smoke.

FIRST AID MEASURES

Under normal conditions of use, the constituent battery cells are hermetically sealed. Contents of an open (broken) constituent battery cell can cause skin irritation and/or chemical burns. If materials from a ruptured or otherwise damaged cell or battery contact skin, flush immediately with water and wash affected area with soap and water. For eye contact, flush with significant amounts of water for 15 minutes and see physician at once. Avoid inhaling any vented gases. If a chemical burn occurs or if irritation persists, seek medical assistance. Seek immediate medical assistance if an electrical shock or electrocution has occurred (or is suspected).

17.06 Description of fuel-fired heater / fuel tank evaporative system

Not applicable; vehicle is not equipped with fuel-fired heater.

18.00 FUEL ECONOMY DATASETS

Model 3 - Long Range AWD, Long Range AWD Performance

	3D218-008371
CD UDDS Test	JTSL10054423
AC Recharge Energy, kWh	89.577
(AER) Unadjusted, Miles	455.32
CO2 Composite Adjusted	0 g/mi (factors into 0 g/mi on FE label)
CD Highway Test	JTSL10054424
AC Recharge Energy, kWh	89.577
(AER) Unadjusted, Miles	422.70
CO2 Composite Adjusted	0 g/mi (factors into 0 g/mi on FE label)

E.O.#: Page:

2019 MODEL-YEAR AIR RESOURCES BOARD
 SUPPLEMENTAL DATA SHEET
 ZEV-PASSENGER CARS, LIGHT-DUTY TRUCKS AND MEDIUM DUTY VEHICLES

Model 3 - Long Range AWD, Long Range AWD Performance

Manufacturer	Tesla, Inc
Engine Family	KTSLV00.0L23
Vehicle Class (es)	Passenger Car
Number of ZEV Credits per vehicle	4
Fuel Type (s)	Electro-Chemical Battery
Battery Type (s)	Lithium Ion
Total Battery Weight, Kg	480
Total Battery Volume, m3	0.400
Battery Specific Energy, Wh/Kg	150
Number of Batteries or modules per vehicle	1
Total Battery Voltage, Nominal	350
Charger(s)	On-Board
Charger(s)	Conductive
Drive Motor (Rear)	Other (Specify) - AC Permanent Magnet
Number of Drive Motor (s)	1
Rated Motor Power, kW - AWD Performance	211
Rated Motor Power, kW - AWD	188
Drive Motor (Front)	AC Induction
Number of Drive Motor (s)	1
Rated Motor Power, kW	147
Drive	4WD-FT
Regenerative Braking	Yes
Regenerative Braking	AW
Driver Controlled Regen Braking	No
Coast Regen Braking	Yes
Air Conditioning	Yes
Fuel-Fired Heater	No
Vehicle Models (If coded, see attachments)	Model 3 - Long Range AWD, Long Range AWD Performance
Transmission Type: M5, A4 (if applicable)	AV/1
GVWR, lbs	4992
Curb Weight, 33%, lbs	4099
Loaded Vehicle Weight	4399
ETW or Test Weight, lbs	4500 (4376 -4625)
DPA / RLHP or Dyno Set Coefficient, a= , lbf	-11.35
DPA / RLHP or Dyno Set Coefficient, b= , lbf/mph	0.1804
DPA / RLHP or Dyno Set Coefficient, c= , lbf/mph^2	0.01082

Range Test Results

Vehicle ID	3D218-008371
Transmission	AV/1
ETW	4500 (4376 -4625)
RLHP	10.90
City Range, miles	455.32
System AC, Wh/mile	196.7
System DC, Wh/mile	177.3
Vehicle DC, Wh/mile	174.0
Highway Range, miles	422.7
System AC, Wh/mile	211.9
System DC, Wh/mile	190.9
Vehicle DC, Wh/mile	187.4
Battery Test Results - Specific Energy, wh/kg	150
Fuel-Fired Heater Emission Results, g/mile	Not applicable

EPA EV Multicycle Calculator (SAE J1634 Oct 2012)

Manufacturer: Tesla Inc.
Carline: Model 3 - Long Range AWD, Long Range AWD Performance
Model Year: 2018
Vehicle: 3D218-008371
Test Number: Internal test #
Comments:
Lab: Tesla Lab - Fremont
Test Date: 4/8/2018

As used by EPA laboratory

D.Good March 8, 2016

Cycle	Energy (Wh)	Distance (mi)	ECdc_cyc	Kuwgt	Kwgt	Recharge AC WattHrs
UDDS1	1489.4000	7.459	199.68	49.92	3.75	89577
UDDS2	1326.1000	7.453	177.93	44.48	58.19	
UDDS3	1271.5000	7.467	170.28	42.57	55.69	
UDDS4	1285.6000	7.463	172.26	43.07	56.34	
HWY1	1950.9000	10.266	190.04	95.02		
HWY2	1895.5000	10.258	184.78	92.39		
SS1	64945.5000	344.048	188.77			
SS2	5053.9000	25.983	194.51			
TOTAL	79218.40	420.397				

K-Factors	UDDS1	UDDS2	UDDS3	UDDS4	HWY1	HWY2
Unweighted	0.250	0.250	0.250	0.250	0.500	0.500
Weighted	0.019	0.327	0.327	0.327	NA	NA

Results	Range (mi)	AC Wh/mi	EPA version	
			MPGe	kWh/100mi
UDDSu	440.01	203.58		
UDDSw	455.32	196.73	171.3229	19.6734
HWY	422.70	211.91	159.0501	21.1914

Derating Factor 0.7032 Ratio of 5-cycle Combined FE to 2-cycle Combined FE
Sticker Range 310 mi
Sticker MPGe 116

Note:

1. Fill in yellow shaded areas to compute range and AC wh/mi results
2. Weighted results based on SAE J1634 calculations
3. Final values in green shaded area should be rounded to appropriate significant digits

3.03 Vehicle Configuration and sub-configurations

Make Carline Type Test Group Final Drive ratio Emission Control Exhaust Evap Model Type Basic Engine code (F/R) Transmission Type / Code Vehicle ID tested	Tesla Model 3 Battery Electric Vehicle JTSLV00.0L23 9.04 NA (BEV) NA (BEV) NA (BEV) Model 3 - Long Range AWD, Long Range AWD Performance L23 AV/1 3D218-008371
Vehicle Configuration # Gross Vehicle Weight (lbs) 33% Curb Mass (lbs) Loaded Vehicle Weight (lbs) Equivalent Test Weight (lbs) Base wheel / Tire (F&R) Target Road Load A lbf B lbf/mph C lbf/mph ² RLHP @ 50mph	0 4992 4099 4399 4500 (4376 -4625) 235/45 R18 - 42 PSI 41.72 0.0515 0.01498 10.9
Sub configuration # Gross Vehicle Weight (lbs) 33% Curb Mass (lbs) Loaded Vehicle Weight (lbs) Equivalent Test Weight (lbs) Wheel / Tire Target Road Load A lbf B lbf/mph C lbf/mph ² Road Load HP @ 50mph	1 4992 4099 4399 4500 (4376 -4625) 235/40 R19 - 42 PSI 45.99 0.0651 0.01554 11.7
Sub configuration # Gross Vehicle Weight (lbs) 33% Curb Mass (lbs) Loaded Vehicle Weight (lbs) Equivalent Test Weight (lbs) Base wheel / Tire (F&R) Target Road Load A lbf B lbf/mph C lbf/mph ² RLHP @ 50mph	2 5071 4124 4424 4500 (4376 -4625) 235/35 R20 - 42 PSI 49.39 0.0914 0.01631 12.6

Fuel Economy Data Vehicle (FEDV) Selection Justification – FEDV curb mass vehicle accounts for options that have a greater than 33% take rate and highest sold wheel/tire combination that collectively represents a vehicle configuration / sub configuration that has the largest sales volume within that Model Type. Tesla affirms that the road load power, and the target coefficients are those that are appropriate for the ETW of the vehicle.